

REV.	ECN NO.	Revision record	Date

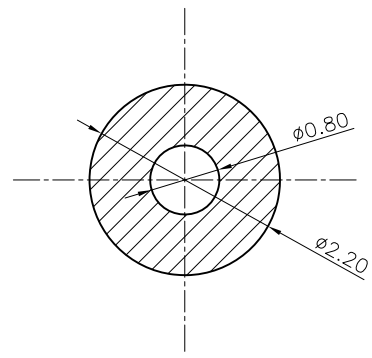
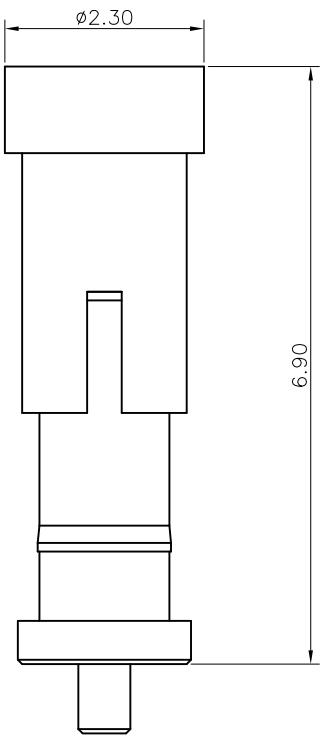
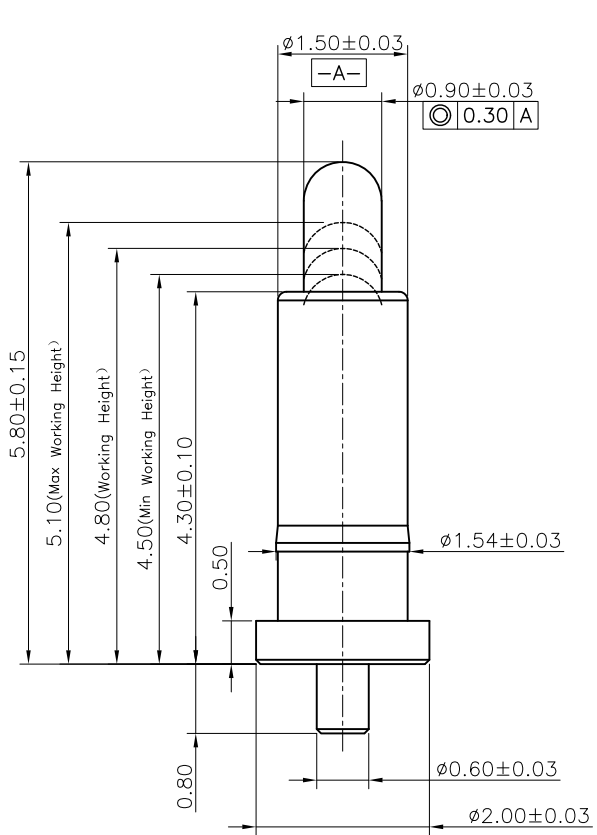

Recommended PCB Layout

- Notes:
- Mechanical performance  
Working Height Force: 30±6gf  
Durability:10000 Cycles
  - Electrical performance  
Current rating: 2.0A  
Voltage rating: 12VAC/DC  
Dynamic Resistance:50mOhm Max.
  - Environmental performance  
RoHS & HF compliant.  
Salt Spray: 48h Min  
Operating Temperature range: -40°C~+85°C
  - Packaging:  
Carrier tape

4	CAP	1	High temp Plast UL94 V-0	Black
3	Body	1	Leaded Brass	Au plating 5u" min over Ni plating 50-100u" min
2	Plunger	1	Leaded Brass	Au plating 10u" min over Ni plating 50-100u" min
1	Spring	1	Stainless steel wire	NA
Item	Part Name	Q'TY	Material	Finish

UNLESS OTHERWISE SPECIFIED  
DIMENSION ARE IN MILLIMETERS  
TOLERANCE ARE :  
FRACTION DECIMALS ANGLES

**Shenzhen Chunni Electronics Co. Ltd.**

.X ±0.15 .XX ±0.10 .XXX ±0.05	X' ±2.0° .X' ±1.5° .XX' ±1.0°	DRAWN	Adrew	Title:	Pogo PIN
		CHECKED	Adrew	Part NO:	CNH15058-0082
		APPROVED		Customer NO:	ME-834 顶针
Unit: mm	Scale: 1:1	CONFIDENTIAL		Page:	1/1
				Rev:	02