

REV.	ECN NO.	REVISION RECORD	DATE
01	ECN-NO	INITIAL RELEASED	20201027

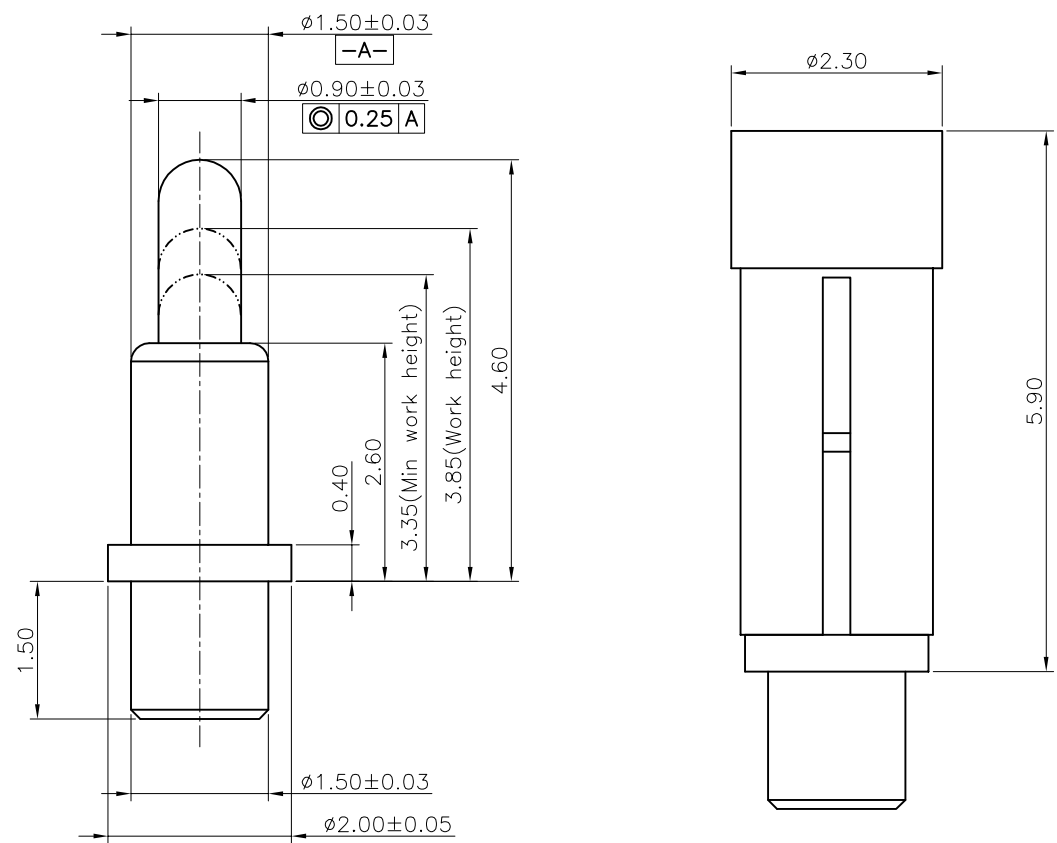

- NOTE:
- Electrical:
 - Rated voltage:AC/DC12V.
 - Rated current:1A Max.
 - Contact resistance: 100 mohm maximum at working height(quiescence)
 - Mechanical:
 - Force:25±10gf at Normal Working Height
 - Durability:10,000 cycles (minimum)
 - Environment:
 - Temperature range: -20 to 85 degrees
 - Salt Spray: 48h Min
 - Wave solder:The temperature of the solder shall be 260±5 °c and immersion duration 5s.
 - RoHS & HF compliant.
 - Please operate it based on the working height Based on the engineering drawings,shall not exceed the maximum allowed compression

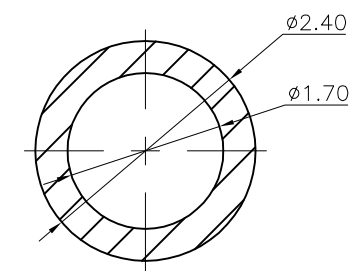

RECOMMENDED PCB LAYOUT(TOP VIEW)
DEFAULT TOLERANCE:±0.05

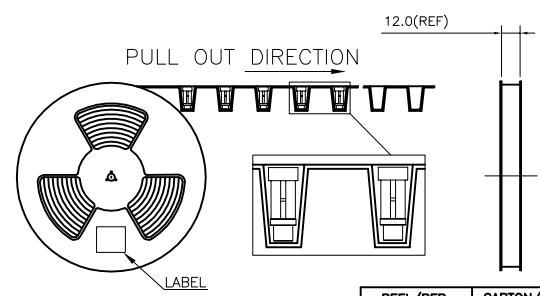
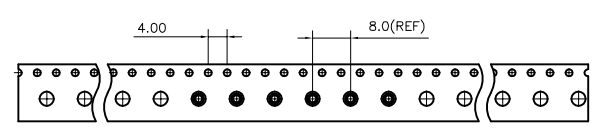

REEL/PER	CARTON/PER
xxx(REF)	xxxx(REF)

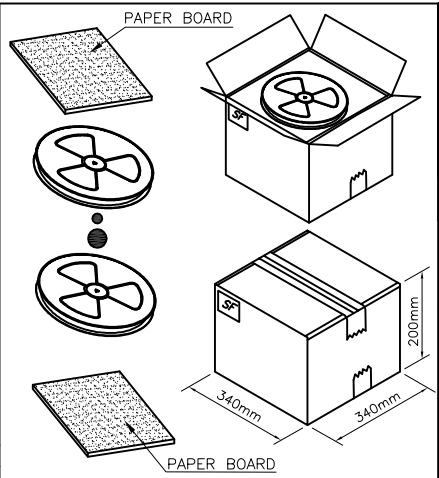

4	CAP	1	High temp Plast	Black,UL94 V-0			
3	Body	1	Leadfree Brass	Au plating 3u" min over all Ni plating 50u"min			
2	Plunger	1	Leadfree Brass				
1	Spring	1	Stainless steel wire				
Item	Part Name	Q'TY	Material	Finish			
UNLESS OTHERWISE SPECIFIED DIMENSION ARE IN MILLIMETERS TOLERANCE ARE : FRACTION DECIMALS ANGLES							
Shenzhen Chunni Electronics Co. Ltd.							
.X	±0.15	X.*	±8°	DRAWN	Evan Pei	TITLE: POGO PIN	
.XX	±0.10	.X*	±5.0°	CHECKED	Evan Pei	PART NO: CNH15046-A03R-00198	
.XXX	±0.05	.XX*	±2.0°	APPROVED	Evan Pei	DRAWING NO: CNH00198R	
Scale: 1:1		Unit: mm		CONFIDENTIAL		Page: 1/1	Rev: 01