

REV.	ECN NO.	Revision record	Date

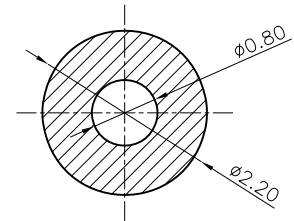
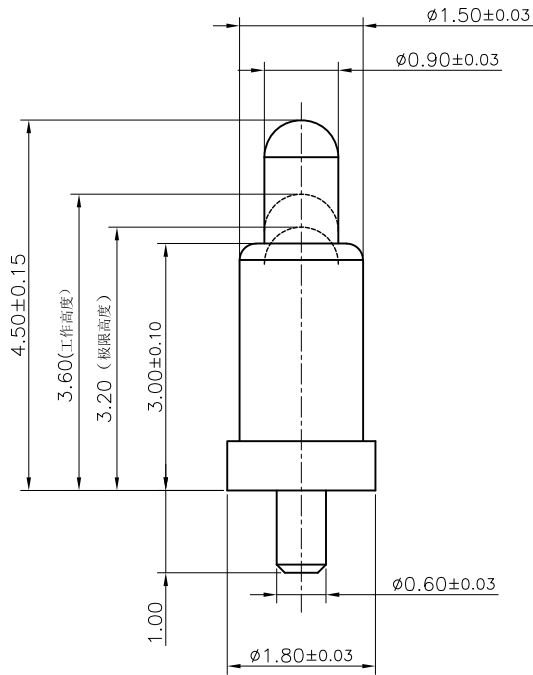
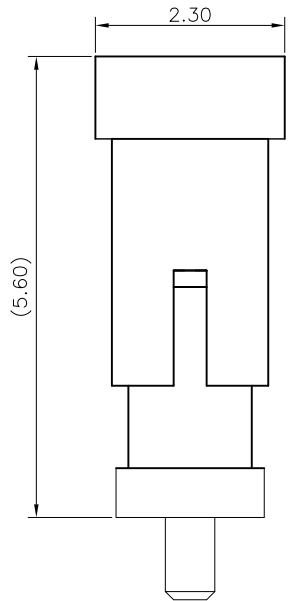

Recommended PCB Layout

Notes:

- Mechanical performance
Working Height Force: $35 \pm 10gf$
Durability: 10000 Cycles
- Electrical performance
Current rating: 1.0A
Voltage rating: 36VAC/DC
Dynamic Resistance: 100mOhm Max.
- Environmental performance
RoHS & HF compliant.
Salt Spray: 48h Min
Operating Temperature range: $-40^{\circ}C \sim +85^{\circ}C$
- Packaging:
Carrier tape

4	CAP	1	High temp Plast UL94 V-0	Black
3	Body	1	Leaded Brass	Au plating 3u" min over Ni plating 50-100u" min
2	Plunger	1	Leaded Brass	Au plating 3u" min over Ni plating 50-100u" min
1	Spring	1	Stainless steel wire	-----
Item	Part Name	Q'TY	Material	Finish

UNLESS OTHERWISE SPECIFIED DIMENSION ARE IN MILLIMETERS TOLERANCE ARE : FRACTION DECIMALS ANGLES		Shenzhen Chunni Electronics Co. Ltd.		
.X ±0.15 .XX ±0.10 .XXX ±0.05	X' ±2.0' .X' ±1.5' .XX' ±1.0'	DRAWN	Adrew	Title: Pogo PIN
		CHECKED	Adrew	Part NO: CNH15045-0029
		APPROVED		Customer NO: YH03
	Scale: 1:1	CONFIDENTIAL		Page: 1/1 Rev: 01